



F-35 LIGHTNING II  
**MXU-1072/A ADVANCED TRAVEL POD**



KIHOMAC's MXU-1072/A Advanced Travel Pod offers an updated replacement for the legacy MXU-648 travel pod.

The new design incorporates decades of first-hand maintainer experience, upgrading key features to increase both the capabilities of the pod as well as usability.

# JUST ARRIVED.



KIHOMAC is postured to provide overhaul support and engineering services for the pod.



KIHOMAC is prepared for both national and international sale.



KIHOMAC plans to produce storage racks and trailers for further support.



## USABLE VOLUME



## CARRYING CAPACITY



## MAX ITEM LENGTH

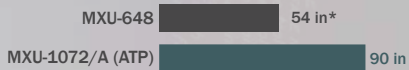

## EMPTY WEIGHT



\*Approx. - Varies by item shape and width.



# F-35 LIGHTNING II MXU-1072/A ADVANCED TRAVEL POD

With a composite construction and a shape specifically designed for the internal carriage space of the F-35, the advanced travel pod more than doubles the usable volume.

The new pod design also offers handles, roll-prevention feet, an integrated tie-down system, and increased accessibility over the legacy pod.

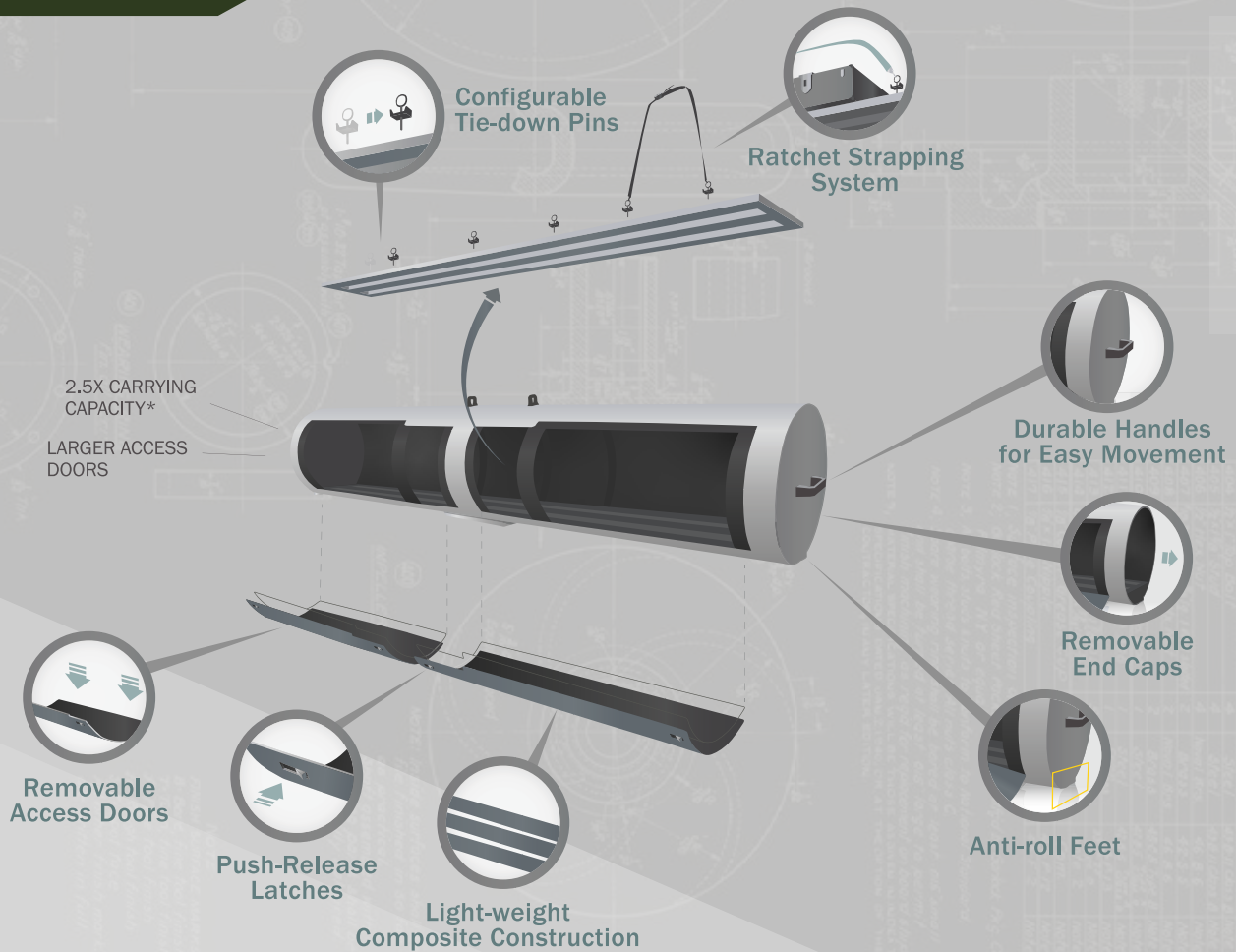
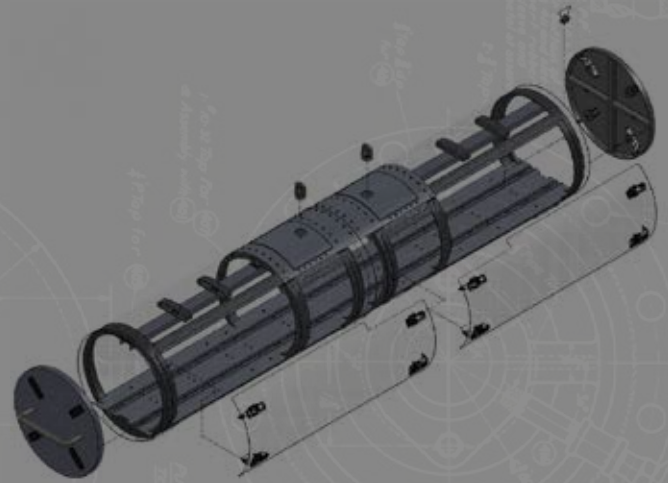

\*Useable volume compared to legacy pod.



**ISO 9001:2015 / AS9100D / CMMI LEVEL 3**



## CONTRACTING INFORMATION

### CONTRACTING VEHICLES

- GSA OASIS Pool 6 SB
- ASTRO
- DevSecOps BOA
- KRACEn
- NAWCAD PLP & FRP
- SeaPort-NxG
- RAPID
- EPIC
- RISE
- EWACC
- Multiple OTAs

### NAICS CODES

- 541715
- 541330
- 336413
- 336411
- 332710
- 333517



## PRICING

**KI HO KANG** 703.786.6512  
kiho.kang@kihomac.com



## TECHNICAL INFO

**TREY MUNN** 801.540.7367  
trey.munn@kihomac.com



## WWW.KIHOMAC.COM

kihomac.virtualtsb.com



## CERTIFICATIONS

- ISO 9001:2015
- AS9100D
- CMMI Level 3
- NADCAP (Composites)
- SAE AS50881
- IPC/WHMA-A-620
- IPC J-STD-001

